



Bleachers and Grandstand Seating

- "L" shaped solid bleachers
- Clear spans up to 28 feet
- Angled ends to allow for direction change





Bleachers and Grandstand Seating

- Solid structure for bolted seat connections
- Caulking provided between precast units
- Float finish appearance





Bleachers and Grandstand Seating

*A Dimension Adjustable 0" to 9 1/4"
*B Dimension Adjustable 0" to 8"

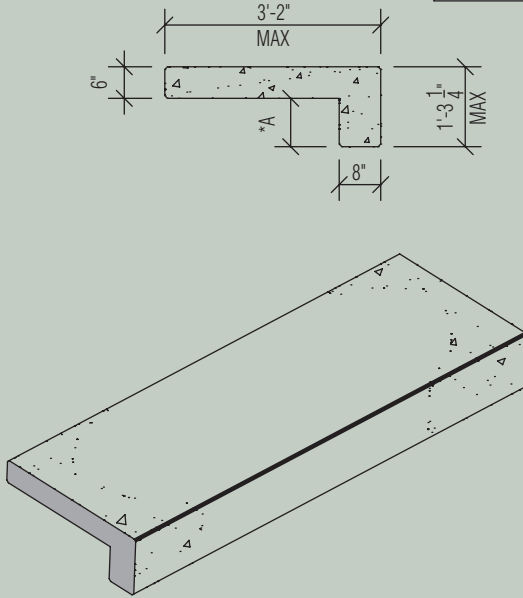

L-Shape Configuration

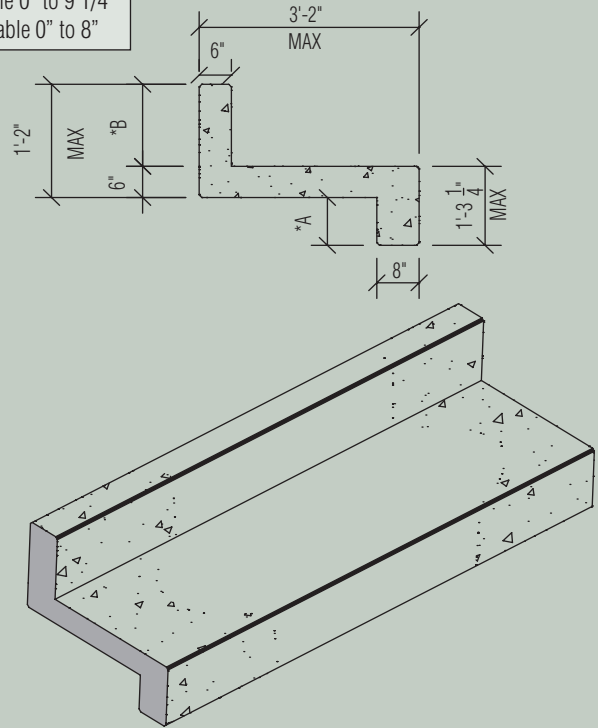

Z-Shape Configuration

- Spans up to 28'-0"
- Float finish top surface
- Steel form finish vertical surfaces
- Beveled edges

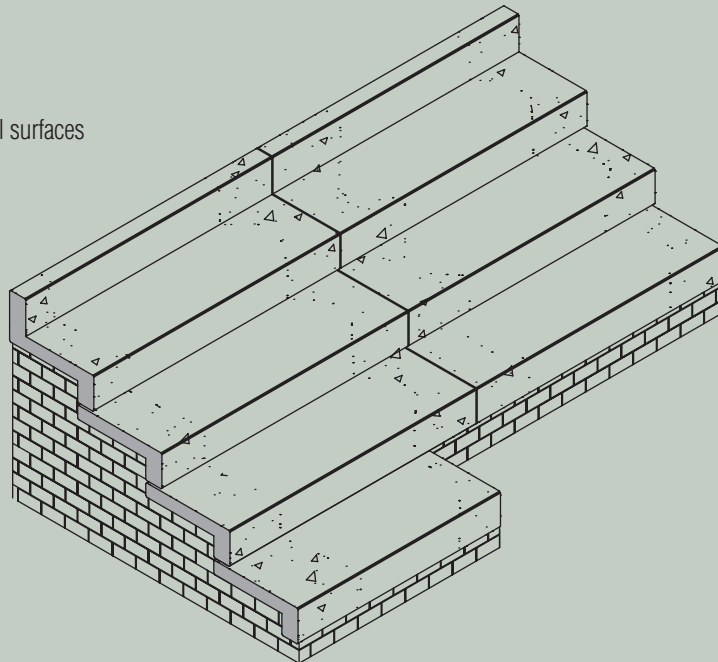

Isometric View

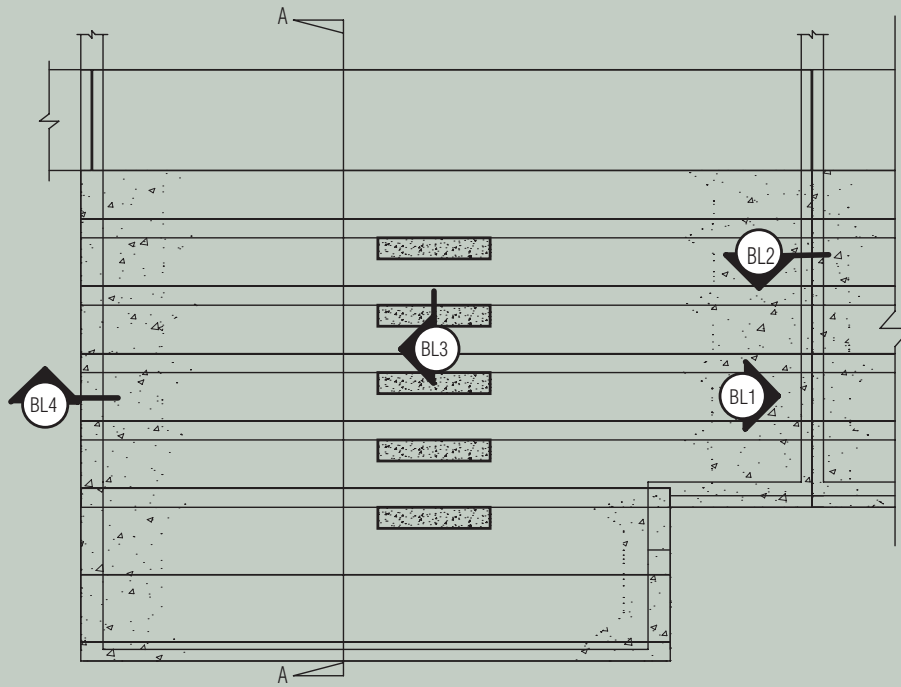

Plan View

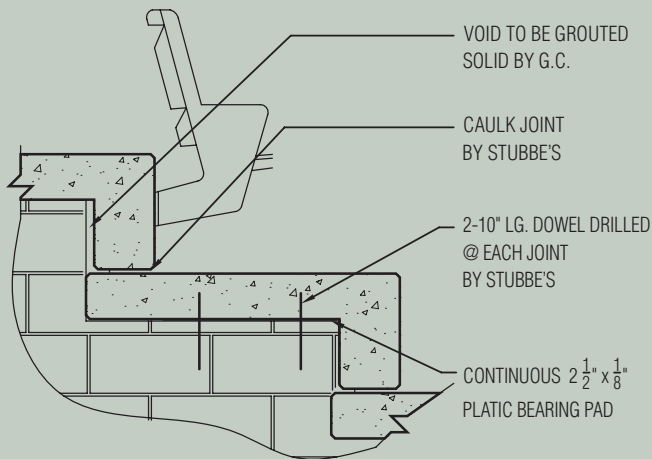

BL1

End View

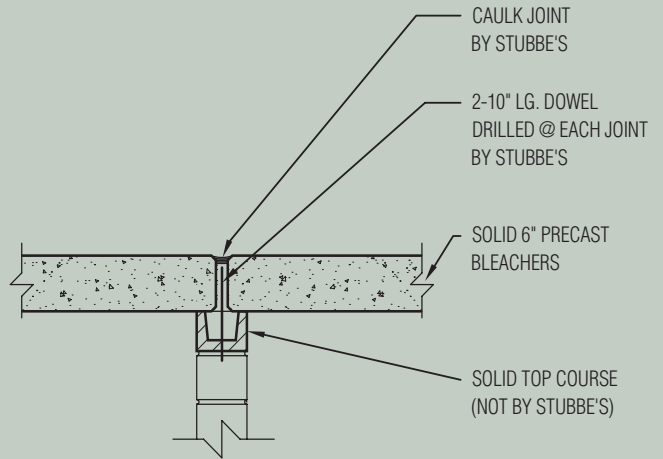

NOTE: MIN $3\frac{1}{2}$ " [89] END BEARING

BL2

End To End Detail



Bleachers and Grandstand Seating

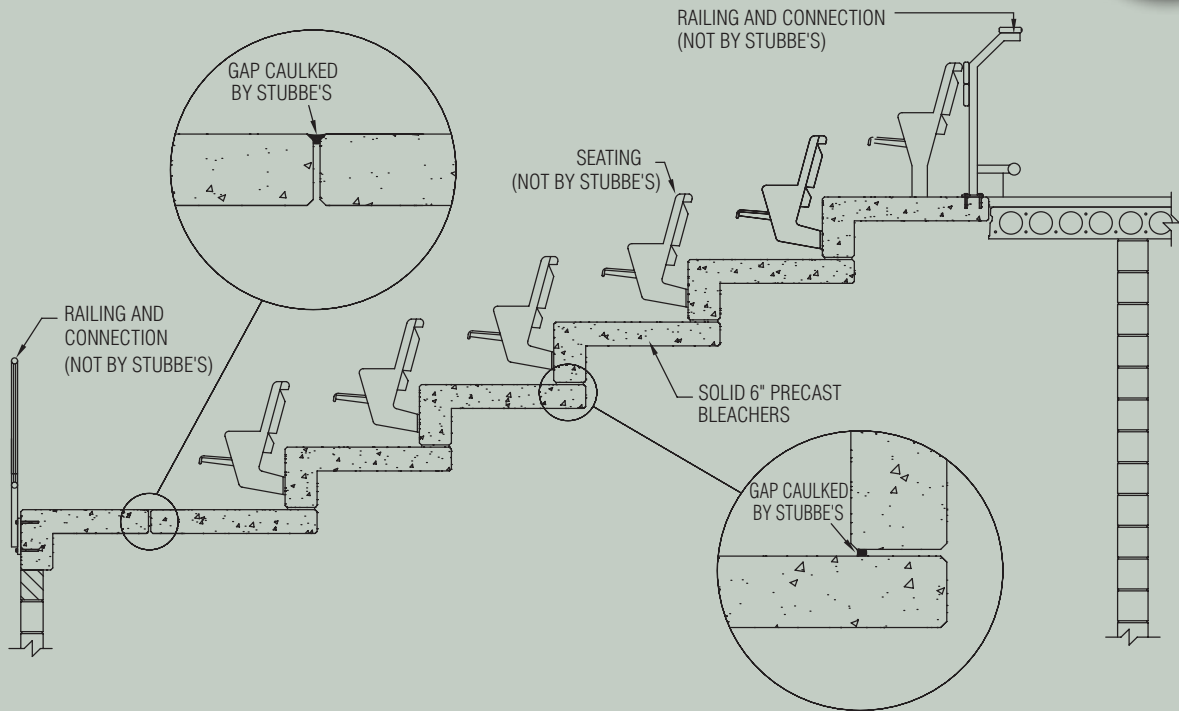

Bleacher Section A-A

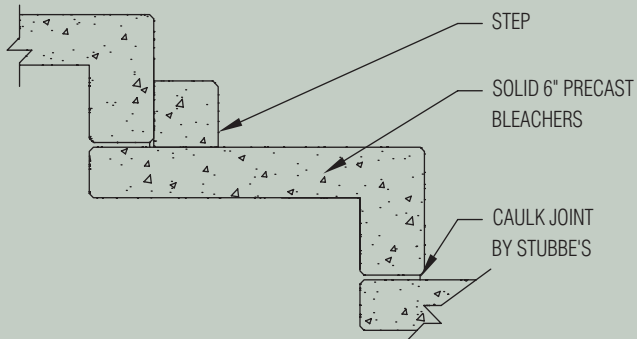

BL3

Typical Section

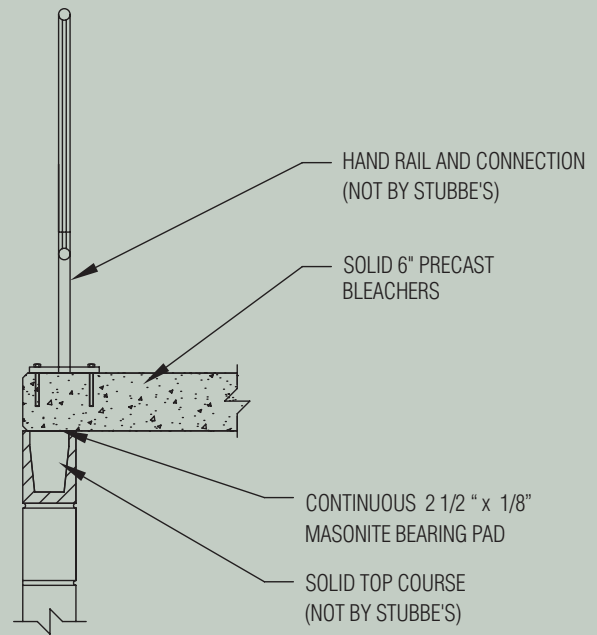

BL4

End Connection